

BFH-45S-180K

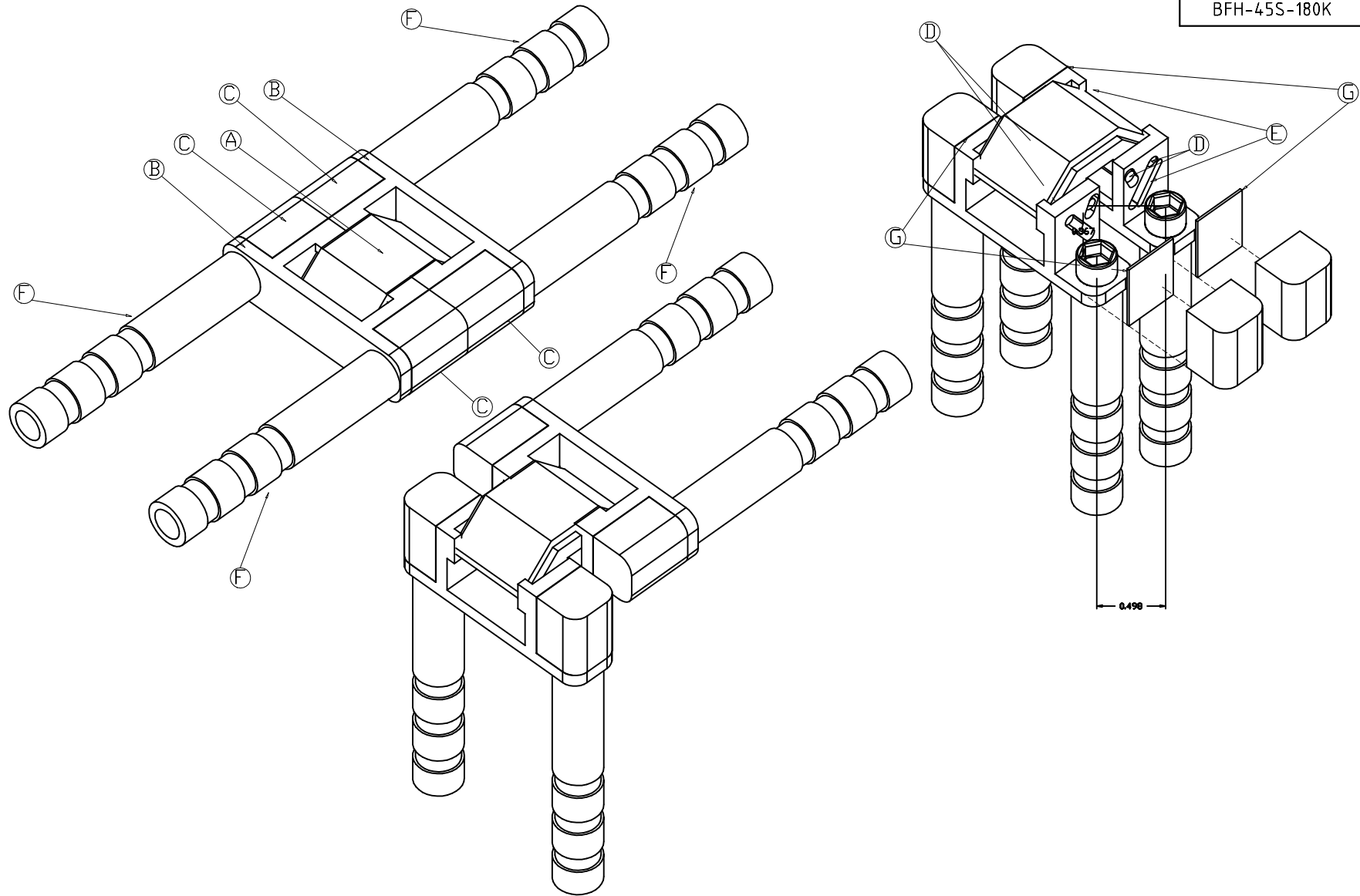

Morgan Hinges, Inc.
 5000 Eldorado Parkway
 Suite 150-317
 Frisco, TX 75033
 (469) 362-8090
 www.morganhinges.com

This hinge consists of the following items:
 (A) One BFH-45S-180 Center Link (see pg. 2)
 (B) Two BFH-45S-180 Side Frames (see pg. 3)
 (C) Four BFH-45S-180 Screw Covers (see pg. 5)
 (D) Four 1" x 3/32" Steel Dowel Pins. Brighton Best or equivalent; min. double shear load of 1800 lbs.)
 (E) Two Restrainers (see pg. 6)

(F) Four optional LM 10/32-2.2 Leg Mounts (see pg. 4)
 (G) Four Pin Covers (see pg. 7)

The individual pieces have tolerances ranging from +/- 0.001 to 0.005. However, they are hand filed to achieve the appropriate fit and the overall tolerances may stack up to 0.010.

Part/Type: BFH-45S-180K	
Material: 6061-T-6511 Aluminum/416 stainless	
Tolerance: +/- 0.005	Units: IN
Revision Date: OCT-11-23	PG: 1/7